

HEADSTOCK-FREE
CLASSIC BOGIE FRAME

Y25Ls(s)1-K CLASSIC BOGIE FRAME

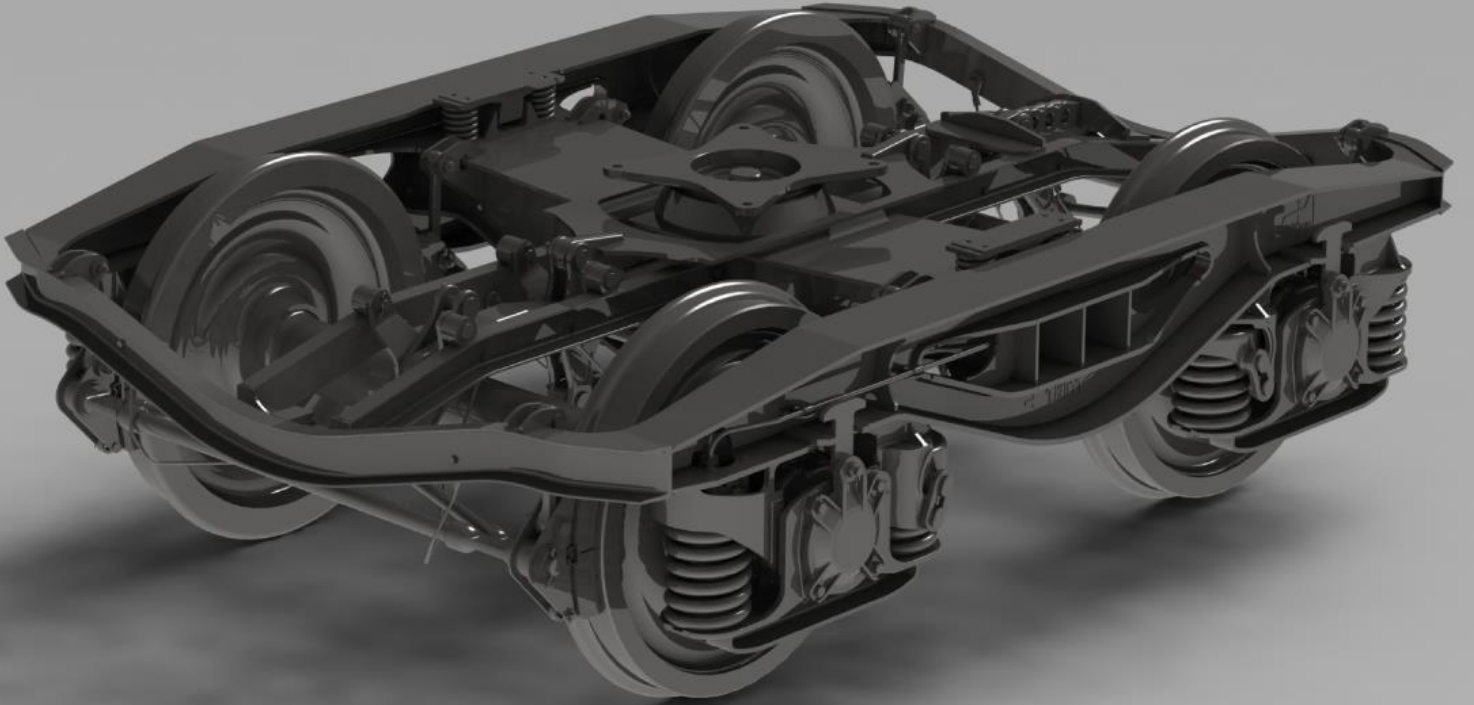

FZK Mühendislik ve Sınai Yatırımlar A.Ş.



www.fzk.com.tr

Y25Ls(s)1-K CLASSIC BOGIE FRAME

DESCRIPTIONS

Features

This standard type of bogie is suitable for various types of freight wagons.

The bogie is TSI certified

The bogie is designed and approved as interoperability constituents in accordance with TSI.

Capabilities

The bogie could be assembled with weighing valve and upper central pivot.

The bogie can be assembled with different equipment according to customer requirements.

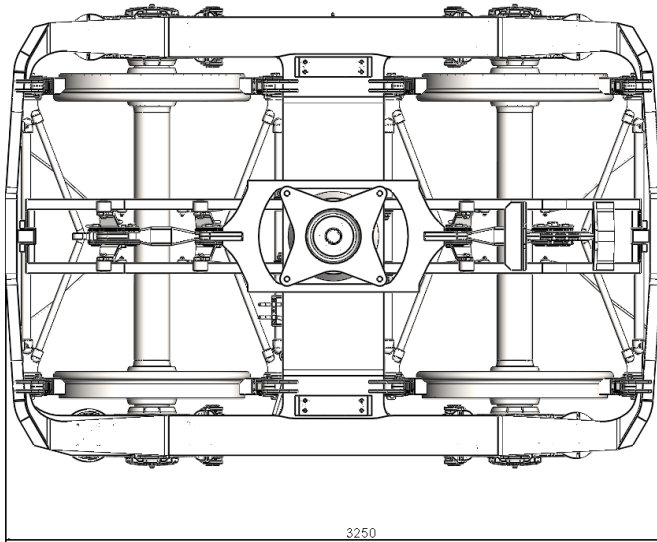
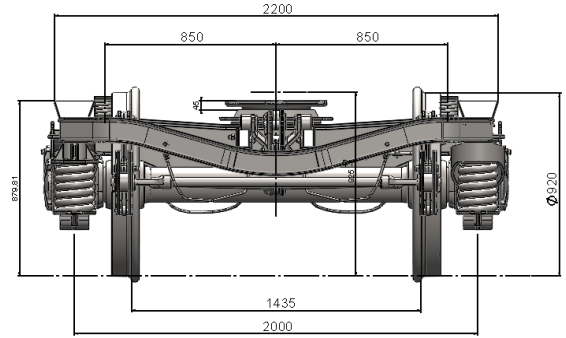
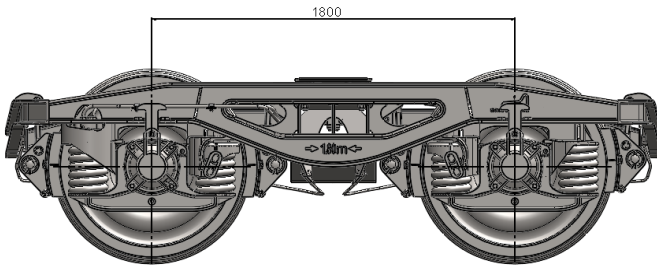

- Axle Load 22,5 t / Axle
- Track gauge 1435 mm
- Loading gauge G1-TSI
- Brake regime S or SS
- Brake shoe K
- Brake shoe holder Bgu
- Max. Speed at 22.5t/axle 100 km/h
- Clima condition T1
- Tare weight From ~4,2 t to ~4,7 t

FZK Mühendislik ve Sınai Yatırımlar A.Ş.



www.fzk.com.tr

HEADSTOCK-FREE
H TYPE COMPACT BOGIE FRAME

Y25LSDI(F)-KC1 H TYPE COMPACT

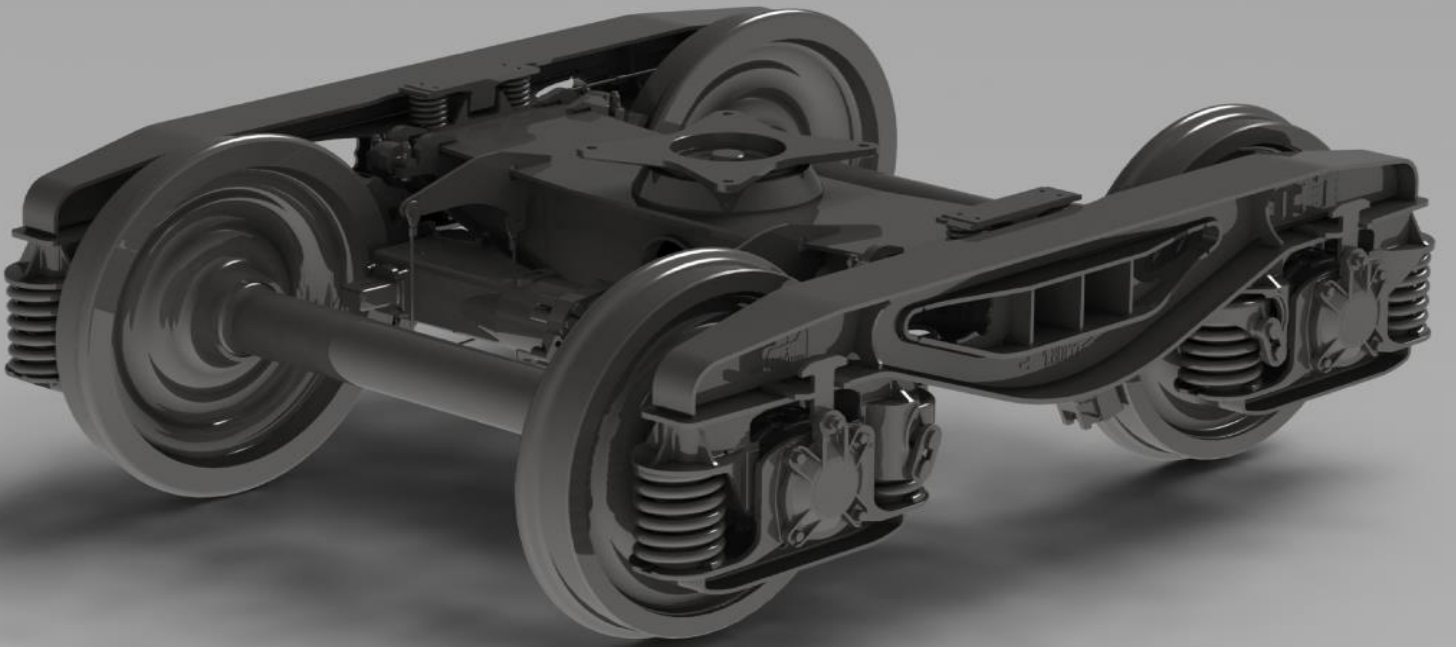

FZK Mühendislik ve Sınai Yatırımlar A.Ş.



www.fzk.com.tr

Y25LSDI(F)-KC1 H TYPE COMPACT

DESCRIPTIONS

Features

This special type of bogie with integrated brake is suitable for furnishing of various types of freight wagons where there is a problem with brake installation directly onto the wagon.

With installation of this type bogie, weight and also space issues are solved.

The bogie is equipped with one Knorr CFCB brake unit.

May be used for RIV and TEN RIV traffic operation.

Capabilities

The bogie could be equipped with weighing valve, upper central pivot and hand brake.

The bogie configuration is variable and has the possibility to be assembled with different equipment according to customer requirements.

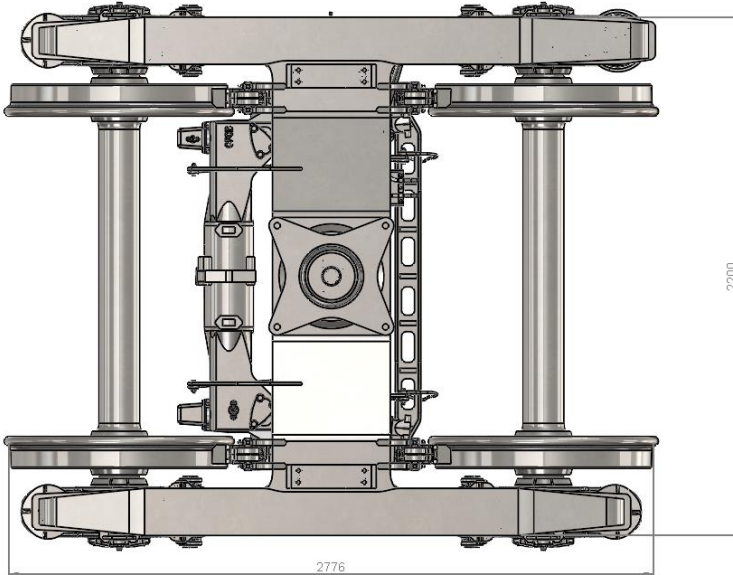
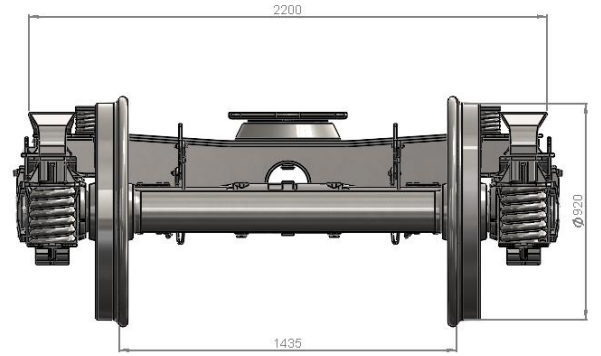
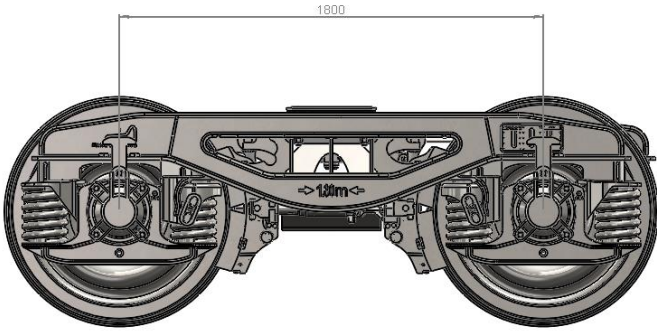

- Axle Load 22,5 t / Axle
- Track gauge 1435 mm
- Loading gauge G1-TSI
- Brake regime S
- Brake shoe K
- Brake shoe holder Bgu
- Max. Speed at 22.5t/axle 100 km/h
- Clima condition T1
- Tare weight ~4,2 t

FZK Mühendislik ve Sınai Yatırımlar A.Ş.



www.fzk.com.tr

HEADSTOCK-FREE
H TYPE COMPACT BOGIE FRAME

Y25LSDI(F)-KC1 H TYPE COMPACT
WITH HAND BRAKE

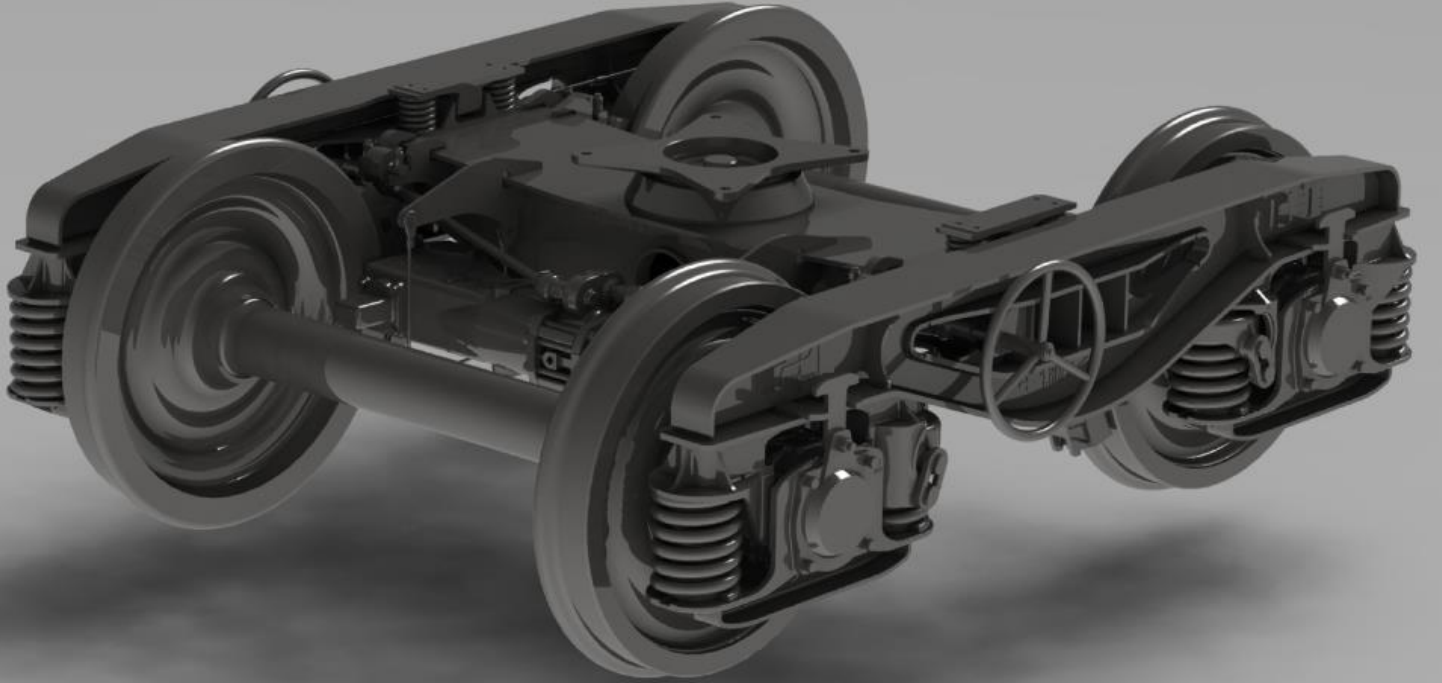

FZK Mühendislik ve Sınai Yatırımlar A.Ş.



www.fzk.com.tr

Y25LSDI(F)-KC1 H TYPE COMPACT WITH HAND BRAKE

DESCRIPTIONS

Features

This special type of bogie with integrated brake is suitable for furnishing of various types of freight wagons where there is a problem with brake installation directly onto the wagon.

With installation of this type bogie, weight and also space issues are solved.

The bogie is equipped with one Knorr CFCB brake unit.

May be used for RIV and TEN RIV traffic operation.

Capabilities

The bogie could be equipped with weighing valve, upper central pivot and hand brake.

The bogie configuration is variable and has the possibility to be assembled with different equipment according to customer requirements.

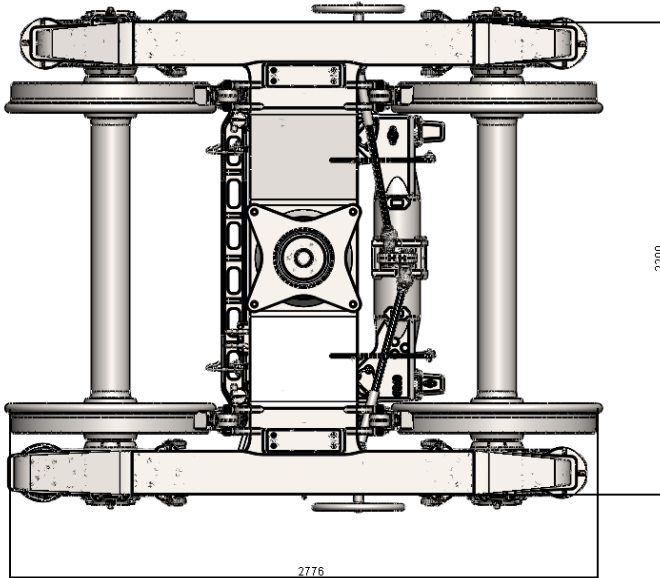
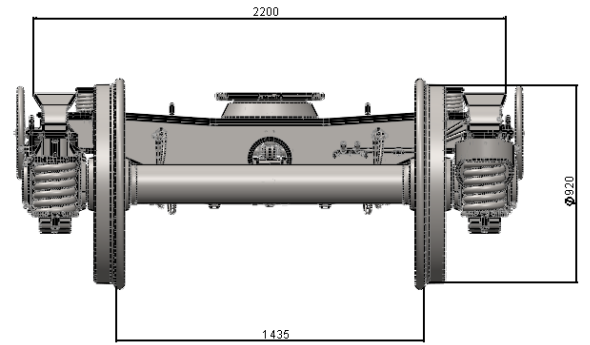
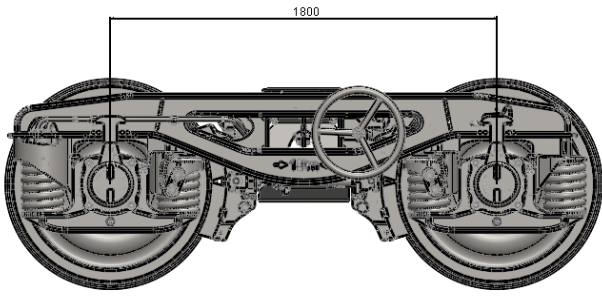

- Axle Load 22,5 t / Axle
- Track gauge 1435 mm
- Loading gauge G1-TSI
- Brake regime S
- Brake shoe K
- Brake shoe holder Bgu
- Max. Speed at 22.5t/axle 100 km/h
- Clima condition T1
- Tare weight ~4,2 t

FZK Mühendislik ve Sınai Yatırımlar A.Ş.

